

rotork[®]

Keeping the World Flowing
for Future Generations

GT Range

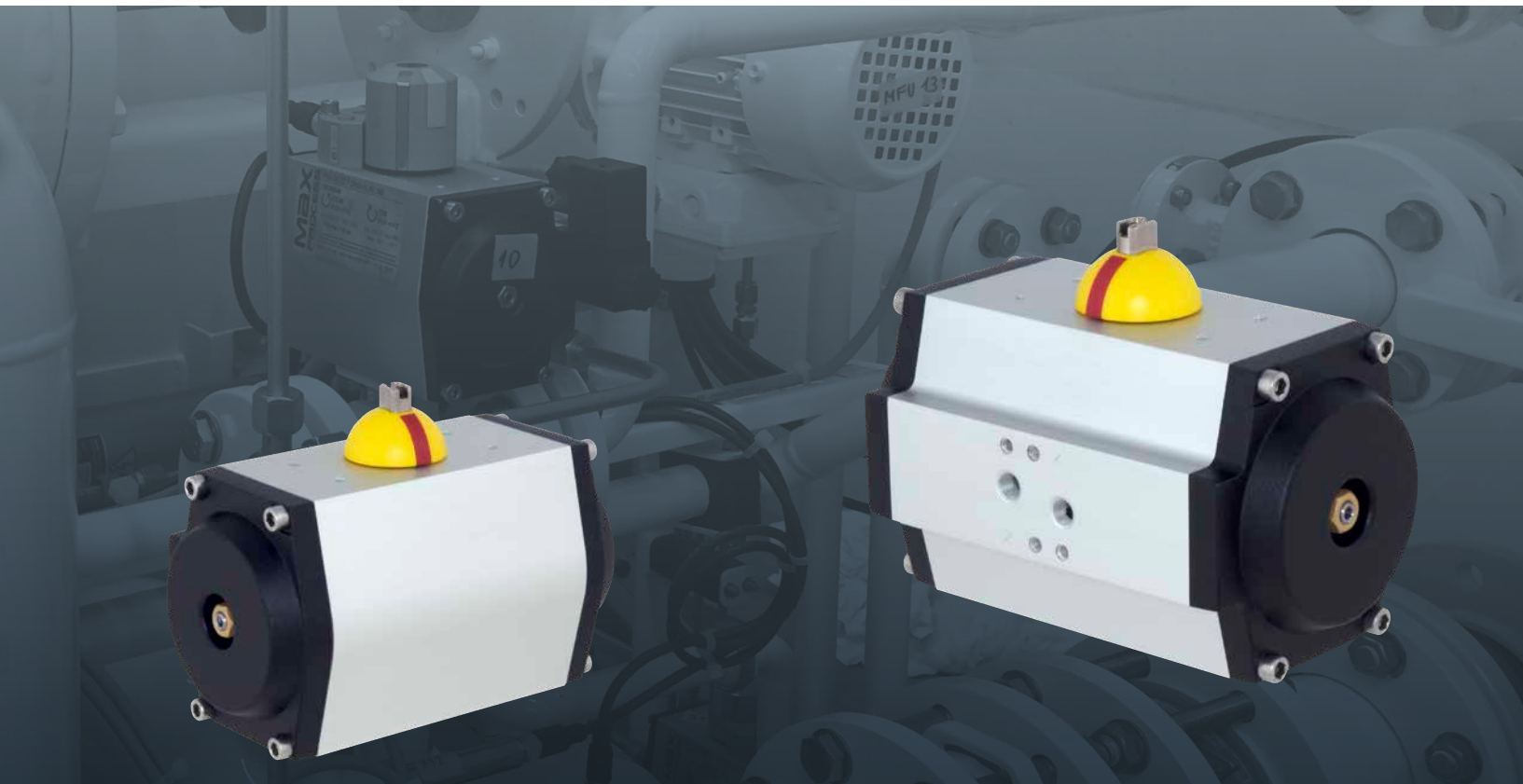

Rack & Pinion Actuators for Rotary Valve Control

GT Range Rack & Pinion Actuators

GT range pneumatic rack & pinion actuators have been proven over a 30-year history of service in hundreds of thousands of installations, encompassing a variety of diverse applications.

There are a wide range of body sizes available in both double-acting and spring-return configurations. Units can be easily changed from one to the other – even in the field. In addition to the usual 90 degree rotation, 120, 180, and 240 degree rotations are also available. All models incorporate an anti-blowout design.

Many options are available to optimise the actuator for particular applications. Options include high- and low-temperature versions, anti-corrosion materials and treatments, valve mounting kits, and declutchable manual gear overrides.

We can also supply actuator control and indication components for virtually any functional requirement and installation environment. Accessory mounting conforms to NAMUR specifications and valve mounting dimensions are per ISO 5211 standards.

Rotork can provide a variety of additional services including application engineering, installation and retrofit, as well as maintenance and repair by factory-trained service personnel.

With superior design, material specification, manufacturing precision, and an industry-best global sales and service support network, Rotork GT range actuators are the wisest choice for any rack & pinion valve actuation requirement.

Every Rotork product is built to provide long and efficient service with a minimum of maintenance. The design, engineering and materials used in the construction ensure optimum performance even in the harshest of environments.

As a global leader in valve actuation technology, we provide a comprehensive range of valve actuators, controls and associated equipment. We also supply a variety of valve actuator services including commissioning, preventive maintenance and retrofit solutions.

Rotork specialises in the production and support of fluid power actuators and control systems. We are dedicated to providing the marketplace with the latest technology, consistently high quality, innovative design, excellent reliability and superior performance.

We maintain dedicated engineering groups for Applications, Product Improvement and New Product Development so that our customers can gain all the benefits that ever-advancing technologies have to offer and to ensure our efforts are in step with the continually evolving needs of our customers.

Most importantly, we have a long-standing commitment to meeting the special needs of a wide range of applications including: oil and gas exploration and transportation; municipal water and wastewater treatment; power generation; and the chemical and process industries.

With over 60 years of engineering and manufacturing expertise, we have tens of thousands of successful valve actuator installations throughout the world.



Fitting Accessories

The Right Accessory Solutions

Valves and actuators only perform as well as the solution is engineered. With decades of experience engineering fluid power valve automation for a multitude of applications and markets, you can depend on Rotork to provide a reliable and safe automation solution to meet your requirements.

In addition to the valve actuator itself, Rotork manufactures a wide range of precision flow control and accessory products as well as a variety of gearboxes and override options. We have designs to withstand the challenges of any valve operating environment.



Inside The GT Actuator

Every Rotork actuator is built to provide long and efficient service with minimum maintenance. The design, engineering and materials used in their construction ensure optimum performance, even in the harshest of environments.

Supply	Filtered air ISO 8573-1:2010
Optional:	Others on request
Operating Pressure	2 to 10 bar (29 to 145 psi)
Torque Output	2.4 to 15,300 Nm (21 to 135,400 lbf.in)

Temperature Ranges

Standard:	-50 to +70 °C (-58 to +158 °F) NBR O-ring, Delrin guide
Optional:	-15 to +160 °C (+5 to +320 °F) Viton O-ring, IXEF guide
Optional:	-60 to +200 °C (-76 to +392 °F) Silicone O-ring, PTFE guide

Mounting Standards

Air supply:	VDI/VDE 3845, NAMUR EN ISO 228 G 1/8" (sizes from 33 to 92) EN ISO 228 G 1/4" (sizes from 110 to 302)
Accessories:	VDI/ VDE 3845, NAMUR
Valve interface:	ISO 5211
Valve shaft interface:	ISO 5211 double square <i>Other interface options available, see Page 9.</i>

Rotation	90°
Optional:	120°, 180°, 240°, or custom angles

Stroke Adjustment	-5° to +5° from 90° position Single- or dual-direction travel stops acting upon the piston(s) ¹
--------------------------	---------------------------------------------------------------------------------------------------------------

Optional:	Extended travel adjustment on the opening stroke is available with installation of a longer stop screw
-----------	--------------------------------------------------------------------------------------------------------

Materials

Body:	Anodised aluminium ASTM 6063
Optional:	Stainless steel AISI 316 (limited sizes) or epoxy paint
Pinion:	Carbon steel EN 11SMnPb3 electroless nickel plated
Optional:	Stainless steel AISI 316
Pistons:	Die-cast aluminium UNI EN1706
End caps:	Die-cast aluminium UNI EN1706, EN AC- 46100, epoxy paint (black RAL 9005)
Spring cartridge:	Carbon steel, epoxy paint

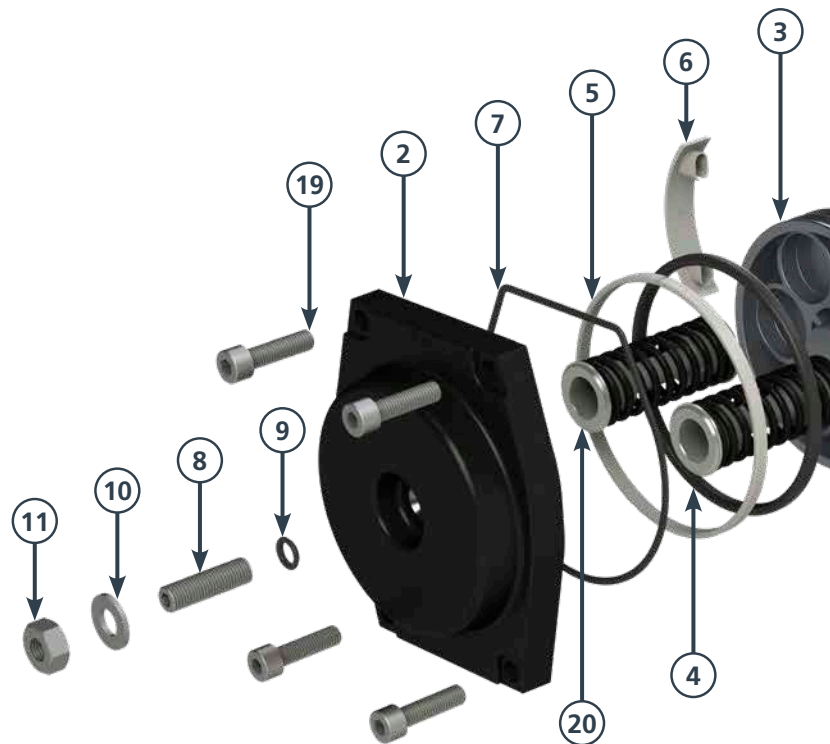

Optional Surface Treatments

- Anodised body, blue epoxy-painted end caps (RAL 5015)
- Hard anodised body, blue epoxy-painted end caps (RAL 5015)
- Hard anodised body, black epoxy-painted end caps (RAL 9005)
- Hard anodised body, end caps, and pistons
- Duraflon PTFE over anodised or hard-anodised body
- Polyester powder coat over anodised body
- FDA compliant epoxy polyester paint over anodised body
- Polyurethane Resin ISO 12944-6 over anodised body
- Plastcoat PPA571 ISO 12944-6 body and end caps

Contact Rotork with other requirements.

Inside The GT Actuator

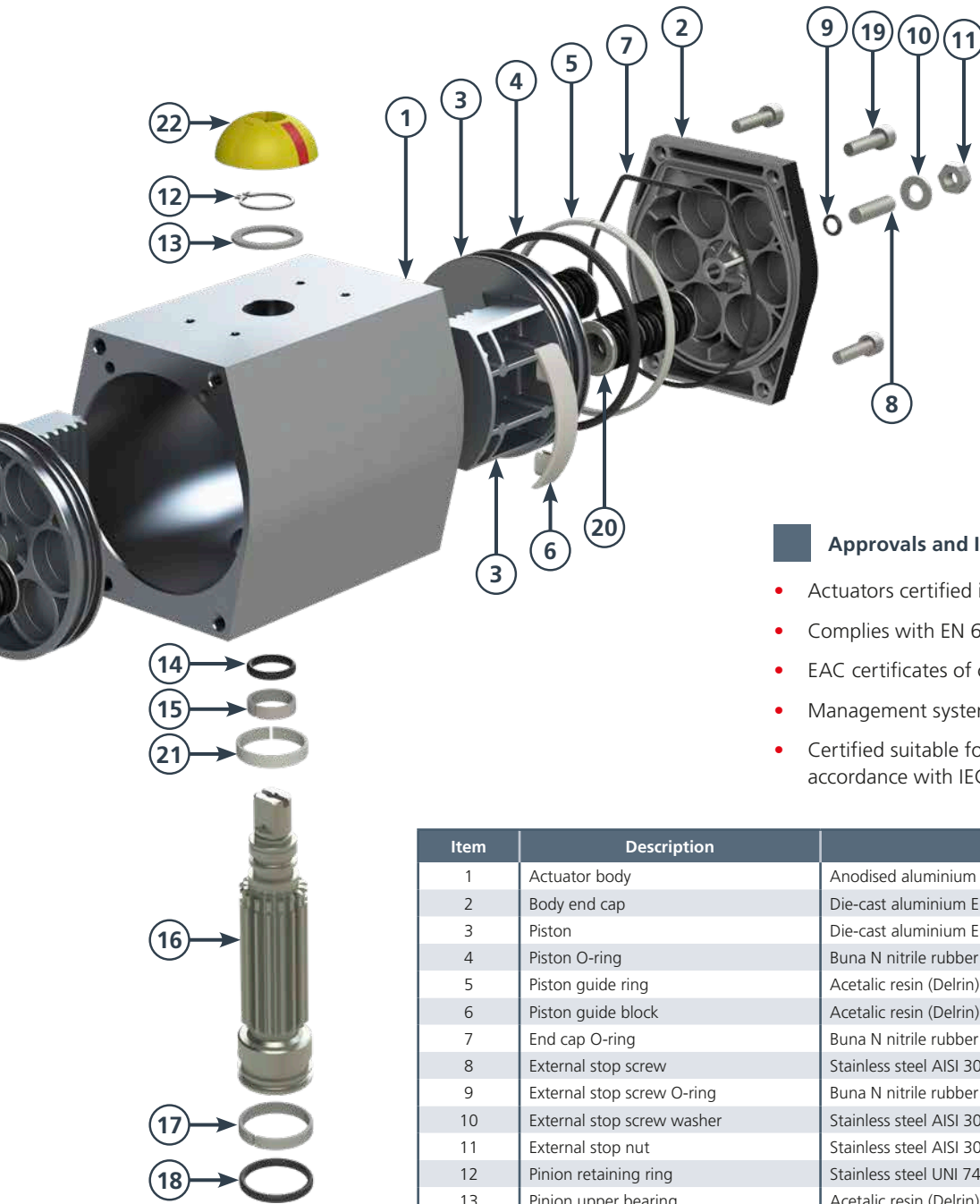

Approvals and Industry Standards

- Actuators certified in accordance with 2014/34/EU
- Complies with EN 60529 (1991) + (A1:2000) for IP66M
- EAC certificates of conformity
- Management system in accordance with ISO 9001:2015
- Certified suitable for use at SIL3 as a single device in accordance with IEC 61508

Item	Description	Material	Quantity
1	Actuator body	Anodised aluminium EN AW6063	1
2	Body end cap	Die-cast aluminium EN AC-46100	2
3	Piston	Die-cast aluminium EN AC-46100	2
4	Piston O-ring	Buna N nitrile rubber	2
5	Piston guide ring	Acetalic resin (Delrin)	2
6	Piston guide block	Acetalic resin (Delrin)	2
7	End cap O-ring	Buna N nitrile rubber	2
8	External stop screw	Stainless steel AISI 304	2
9	External stop screw O-ring	Buna N nitrile rubber	2
10	External stop screw washer	Stainless steel AISI 304	2
11	External stop nut	Stainless steel AISI 304	2
12	Pinion retaining ring	Stainless steel UNI 7435	1
13	Pinion upper bearing	Acetalic resin (Delrin)	1
14	Pinion upper O-ring	Buna N nitrile rubber	1
15	Pinion upper guide bearing	Acetalic resin (Delrin)	1
16	Pinion	Carbon steel EN 11SMnPb3 (electroless nickel plated)	1
17	Pinion lower guide bearing	Acetalic resin (Delrin)	1
18	Pinion lower O-ring	Buna N nitrile rubber	1
19	End cap retaining screws	Stainless steel AISI 304	8
20	Spring cartridge	Steel (epoxy painted)	0-12
21	Anti-blowout ring	Polyarylamide	1
22	Position indicator	Nylon 6	1

1. GT range actuators are available with either single- or dual-direction of travel stop adjustment, except on the smallest sizes, 33, 34, 43, and 44 which do not have any travel adjustment in the standard version. Outboard stop adjustment is +/- 5° (e.g. 85° - 95°). Inboard stop adjustment is +5°/-25°.

The illustration and parts list above depict an actuator with single-direction travel stop adjustment, standard temperature build.

Dimension Data and Mounting Standards

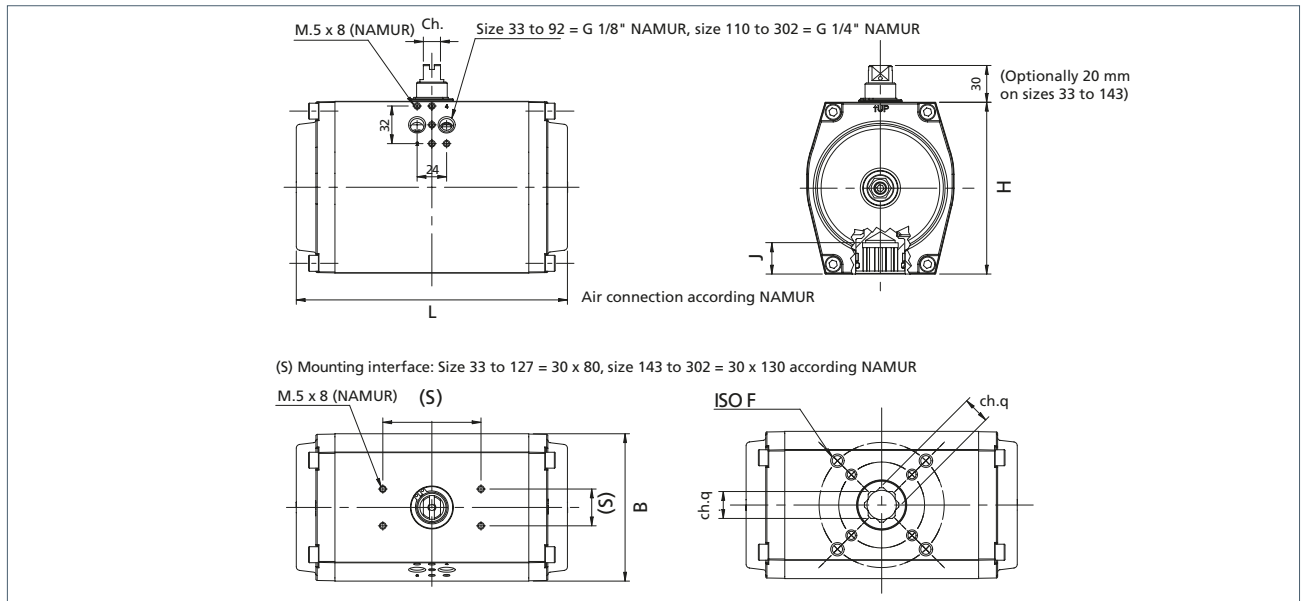

Model	Dimensions (mm)									Displacement (dm ³)				Weight (kg)			
	90°	L		H	J	B	Ch	Ch.q	ISO	SR 90°	90°	DA		SR 90°	90°	DA	
		120°	180°										120°	180°		120°	180°
33	90	-	-	65	13	61.5	10	9/11	F03	-	0.15	-	-	-	0.47	-	-
34	90	-	-	65	13	61.5	10	9/11	F04	-	0.15	-	-	-	0.47	-	-
43	116	-	-	65	13	61.5	10	9/11	F03/F05	0.10	0.18	-	-	0.66	0.60	-	-
44	116	-	-	65	13	61.5	10	9/11	F04	0.10	0.18	-	-	0.66	0.60	-	-
52	133	151	195	74	18	68.5	10	14	F03/F05	0.13	0.25	0.28	0.46	1.00	0.90	1.10	1.30
63	137	155	200	88	20	80	10	14	F05/F07	0.21	0.40	0.45	0.74	1.62	1.45	1.70	2.00
75	161	183	237	100	20	92.5	10	17	F05/F07	0.32	0.60	0.68	1.12	2.45	2.10	2.46	2.90
83	180	205	268	108	20	99.5	10	17	F05/F07	0.45	0.88	1.00	1.63	2.95	2.50	2.95	3.50
92	209	239	310	117	21	110.5	14	17	F05/F07	0.62	1.20	1.35	2.25	4.00	3.40	4.00	4.60
110	223	253	323	140	25.5	120	14	22	F07/F10	0.98	1.90	2.15	3.52	6.20	5.20	6.10	7.20
118	293	345	429	140	36	120	20	22	F07/F10	1.40	2.70	3.05	5.00	8.35	7.10	8.00	9.70
127	301	353	453	160	36	137	20	22	F07/F10	2.00	3.65	4.10	6.80	10.7	9.00	10.0	12.5
143	337	387	488	198	33	172	20	27	F10/F12	2.50	4.60	6.12	9.20	15.8	12.4	14.0	16.0
160	379	444	570	198	39	172	28	27	F10/F12	3.80	7.00	8.00	13.0	20.1	16.4	18.8	26.0
190	422	-	-	255	41	224	28	36	F14	6.50	12.5	-	-	37.8	28.0	-	-
210	468	544	696	255	40	224	32	36	F14	8.00	15.0	17.0	21.5	39.6	31.8	37.4	49.2
253	524	600	751	302	50	272	32	46	F16	10	19.2	22	29	56	44	50	63
254	609	711	911	302	50	272	32	46	F16	14.0	27.0	31.5	41.0	70.6	55.5	66.5	79.8
255	689	815	-	302	50	272	32	46	F16	17.0	32.0	38.0	-	84.3	69.2	77.0	-
300	689	814	-	360	50	360	32	46	F16	25	46	68	-	107.1	92	105	-
300-F25	689	814	-	392	65	360	32	55	F25	25	46	68	-	114	99	112	-
302	1,176	-	-	360	50	360	32	46	F16	46	84	-	-	179	144	-	-
302-F25	1,176	-	-	392	65	360	32	55	F25	46	84	-	-	179	154	-	-

Optional Body Air Connections

- UNI EN ISO 228 G 1/2" (sizes from 110 to 302)
- UNI EN ISO 228 G 3/4" (sizes from 253 to 302)
- UNI EN ISO 228 G 1" (sizes from 300 to 302)

Optional Bottom Flange Drilling

- ISO F04 (for sizes 52, 63, 75)
- ISO F05 (for size 110)
- ISO F07 (for size 143)
- ISO F10 and F12 (for size 190 and 210)
- ISO F12 (for size 127)
- ISO F14 (for size 253)
- ISO F12 and F16 (for size 254)
- ISO F25 (for sizes 300 and 302)

Optional Valve Shaft Interface

- Single square parallel ISO 5212
- Single square diagonal ISO 5213
- Double D

Note: standard is double square ISO 5211.

Model Number Designation

Example Model Number **GTA - 52 - FC - 04 - W - ST**

Range and Rotation

GTA = 90° rotation
GTB = 120° rotation
GTC = 180° rotation

Body Size

33, 34, 43, 44, 52, 63, 75, 83, 92, 110, 118, 127, 143, 160, 190, 210, 253, 254, 255, 300, 302

Effect

DA = Double-acting
FC = Spring-return, fail to close (clockwise)
FO = Spring-return, fail to open (counter-clockwise)

Spring Set

01, 02, 03, 04, 05, 06, 07, 08, 09, 10, 11, 12, 13, 14, 15, 16, 17, 18, 19, 20, 21, 22, 23, 24, 25, 26, 27, 28, 29, 30, 31, 32 (not applicable for double-acting)

Travel Stop

X0 = No end stop (33, 34, 43 and 44 body size only)
K0 = Single direction +/- 5 degrees
K1 = Single direction +5 to -90 degrees
W0 = Dual direction +/- 5 degrees open, +5 to -25 degrees close
W1 = Dual direction +5 to -90 degrees open, +5 to -25 degrees close
Z0 = Blocked end stop

Temperature Range

ST = Standard -50 to +70 °C (-58 to +158 °F)
HT = High -15 to +160 °C (+5 to +320 °F)
ET = Extended -60 to +200 °C (-76 to +392 °F)
SX = Special (consult factory)

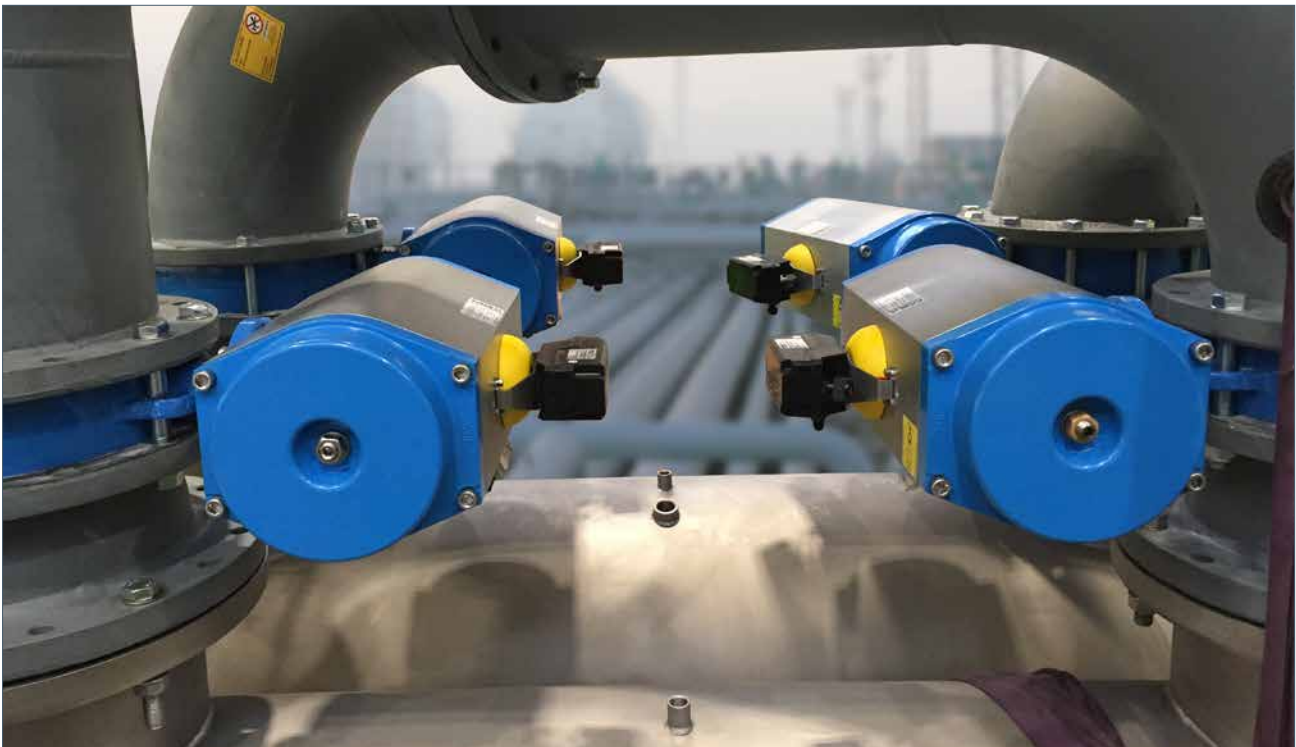

Assembly Configurations

The graphics below show the relative orientation of the piston and pinion for each configuration, as viewed from the top side of the actuator. In the descriptions that follow, that perspective is assumed. Pinion rotation is indicated for each as CW (clockwise) or CCW (counter-clockwise).







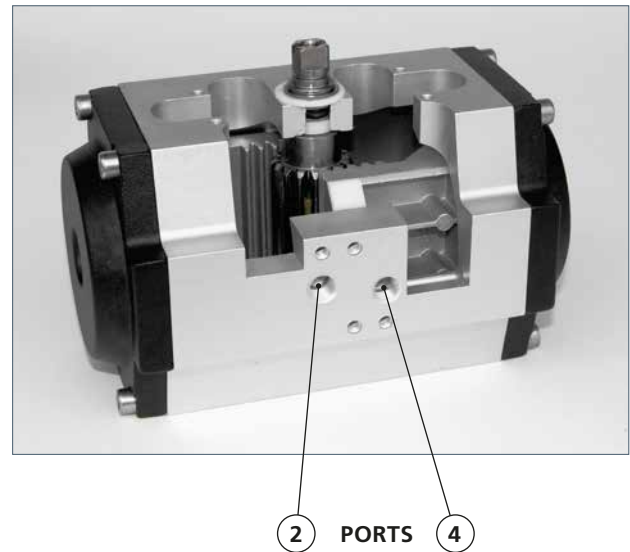

Port 2 is connected to the inboard side of the pistons. Pressurising Port 2 will force the pistons out until they reach the travel stops. The direction of pinion rotation is determined by the assembly configuration. Venting is through Port 4.

Port 4 is connected to the outboard side of the pistons. Pressurising Port 4 will force the pistons in until they reach the travel stops (if the actuator is so equipped as they're optional). The direction of pinion rotation is determined by the assembly configuration. Venting is through Port 2.

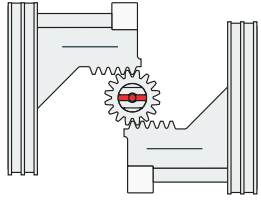
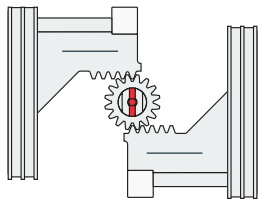
Note that on spring-return actuators, as with double-acting, pressurising Port 2 will move the pistons out. When Port 2 is depressurised, spring force will move the pistons in. Venting is through Port 4. Port 4 is not to be pressurised on spring-return actuators.

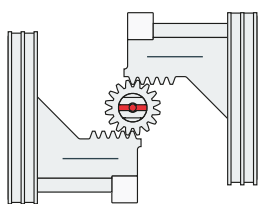
Consult the GT Range Installation and Commissioning Manual or Rotork for detailed connection and operation information.

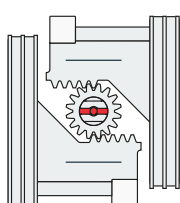

STYLE	PORT 4 (OUTBOARD) PRESSURISED <i>Shown at end of stroke</i>	PORT 2 (INBOARD) PRESSURISED <i>Shown at end of stroke</i>
A STANDARD	 CW 	 CCW 
B OPTIONAL	 CW 	 CCW 
C OPTIONAL	 CCW 	 CW 
D OPTIONAL	 CCW 	 CW 

rotork®



www.rotork.com

A full listing of our worldwide sales and service network is available on our website.

Rotork plc
Brassmill Lane, Bath, UK
tel +44 (0)1225 733200
email mail@rotork.com

PUB110-001-00
Issue 08/22

As part of a process of on-going product development, Rotork reserves the right to amend and change specifications without prior notice. Published data may be subject to change. For the very latest version release, visit our website at www.rotork.com

The name Rotork is a registered trademark. Rotork recognises all registered trademarks. Published and produced in the UK by Rotork. POLJB0622